

## Control Panel

Available apps can vary based on your printer setup. For details about apps and features, refer to the *User Guide*.

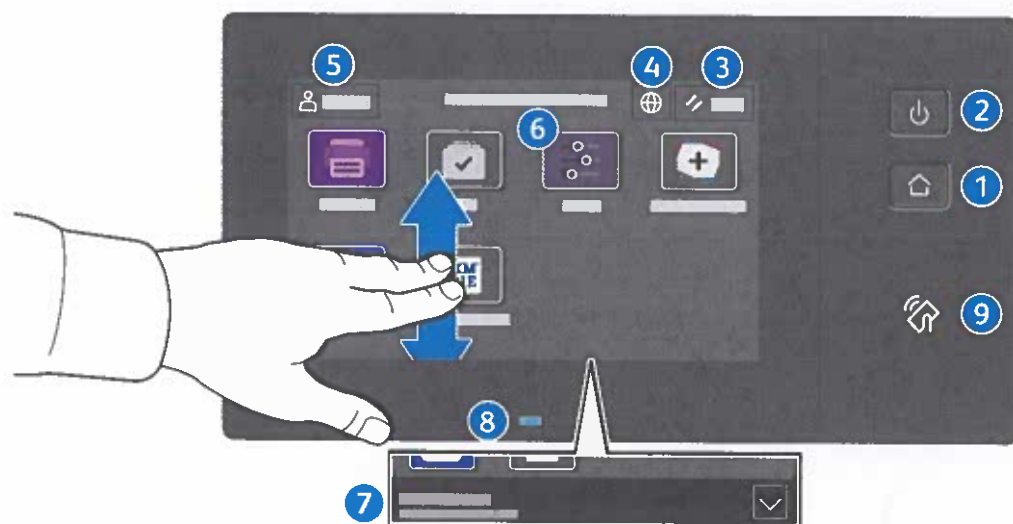

- 1 **Home** returns to the main app screen.
- 2 **Power/Wake** starts the printer or provides options to sleep, restart or power off the printer.
- 3 **Reset** restores settings to their default values in all apps.
- 4 **Language** provides choice of screen languages.
- 5 **Log In** provides special access to tools and settings.
- 6 **Device app** provides access to printer information and settings.
- 7 **Notification banner** shows printer status and warnings. To see all notifications, touch the banner. To close the banner, touch the down arrow.
- 8 **Status LED** indicates printer status. For detailed information, refer to the *User Guide*.
- 9 **NFC Area** allows pairing with a mobile device to print from an app.

## Device app

The Device app provides access to supplies status, printer information, and settings. Some menus and settings require log in with the administrator name and password.



## Billing and Usage Information

In the Device features menu, to view basic impression counts, touch **Billing/Usage**. To view detailed usage counts, touch **Usage Counters**. The list provides detailed impression count categories.

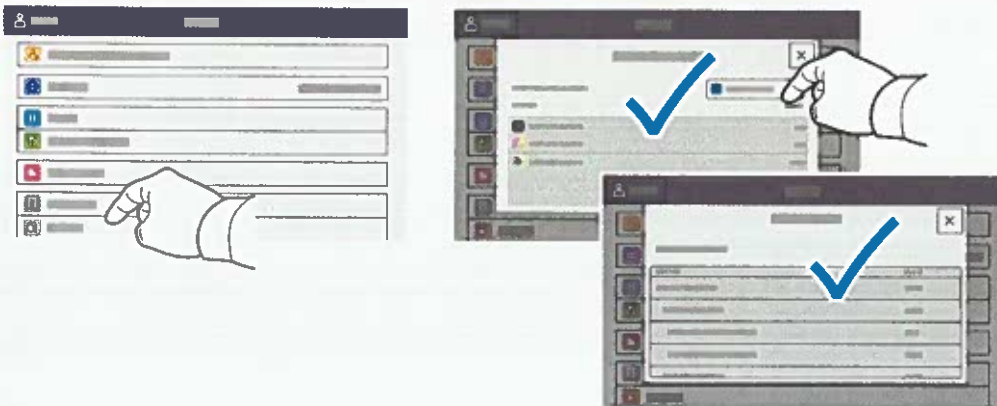

## Embedded Web Server

The Xerox® Embedded Web Server enables you to access printer configuration details, paper and supplies status, job status, and diagnostic functions over a network.

To connect, in a Web browser, type the printer IP address. The network IPv4 address is available on the control panel touch screen. Touch **Device** app > **About**, then scroll down.

For details on using the Embedded Web Server, refer to the *User Guide* located on [Xerox.com](http://Xerox.com).

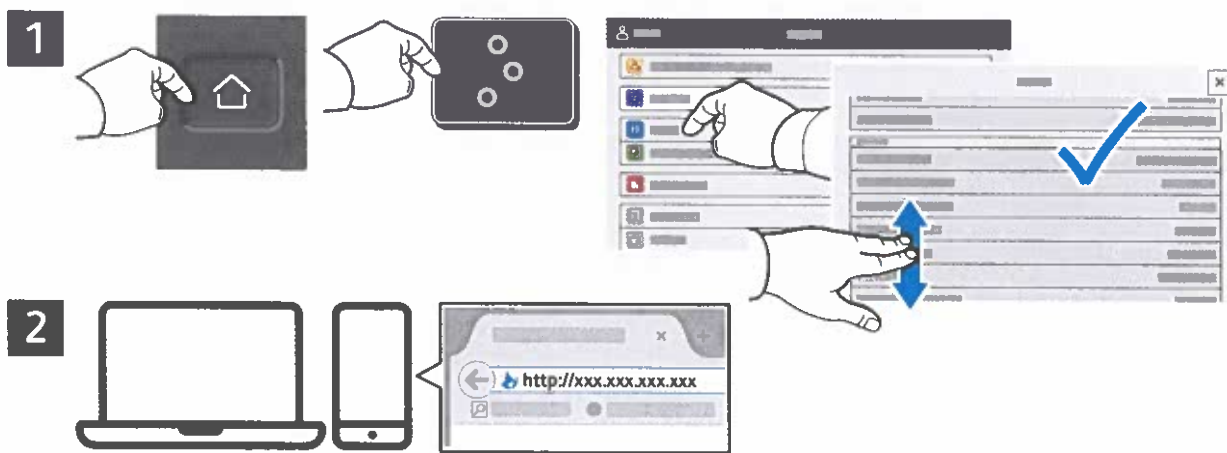

## App Gallery

The Xerox App Gallery has a growing collection of productivity apps that you can install on your printer. Find the app on your home screen and create your login directly, or go to [www.xerox.com/appgallery](http://www.xerox.com/appgallery) to log in and add your device. To simplify app installation, use the same name for your app gallery login credentials that you used for the printer login.

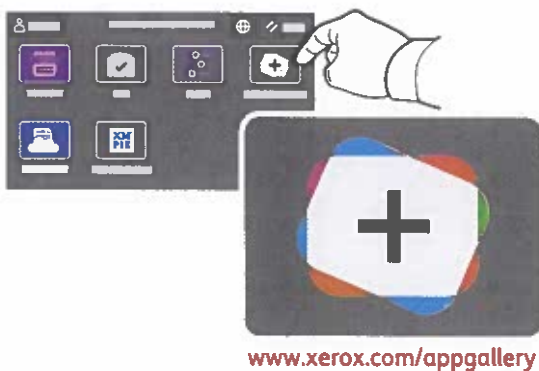

# Printer Tour

Optional accessories can be part of your printer setup. For details, refer to the *User Guide*.

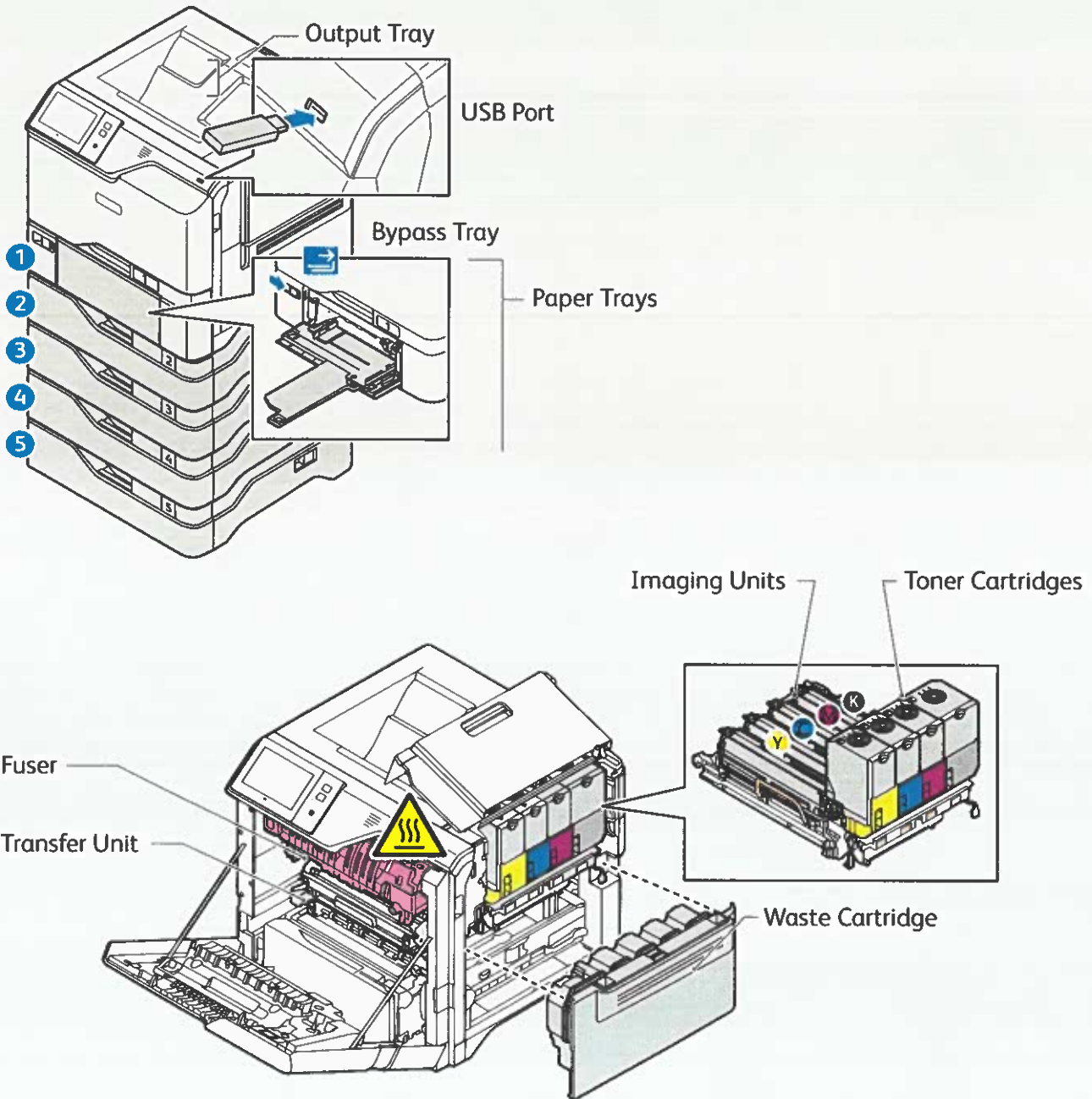

## Paper Handling

For a complete list of paper that works with your printer, see the Recommended Media List at:

[www.xerox.com/rmlna](http://www.xerox.com/rmlna) (U. S. and Canada)

[www.xerox.com/rmleu](http://www.xerox.com/rmleu) (Europe)

For details about trays and paper, refer to the *User Guide*.

## Loading Paper

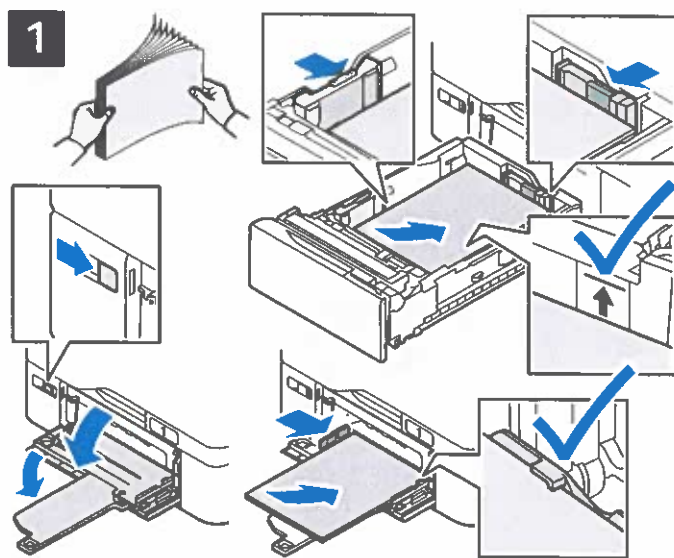

Confirm or change size, type, and color settings if needed.



For the best results, fan the edges of the paper. Adjust the guides to fit the paper size. Do not load paper above the maximum fill line.

When printing, select options in the print driver.

## Paper Orientation

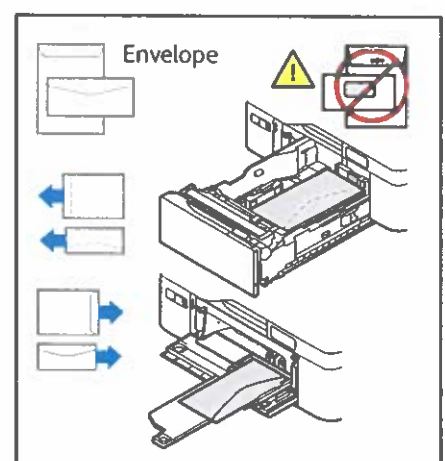
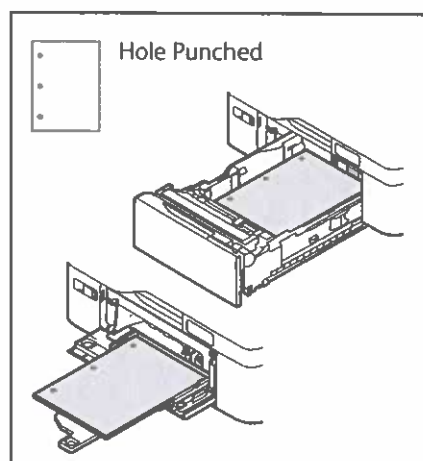
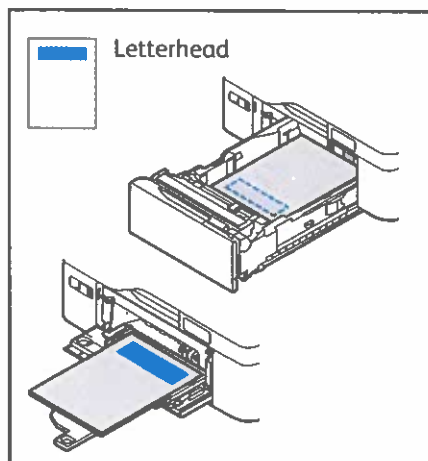

## Printing from a USB Flash Drive

You can print .pdf, .tiff, .ps, .xps and other files types directly from a USB Flash Drive. For more information, refer to the *User Guide*.

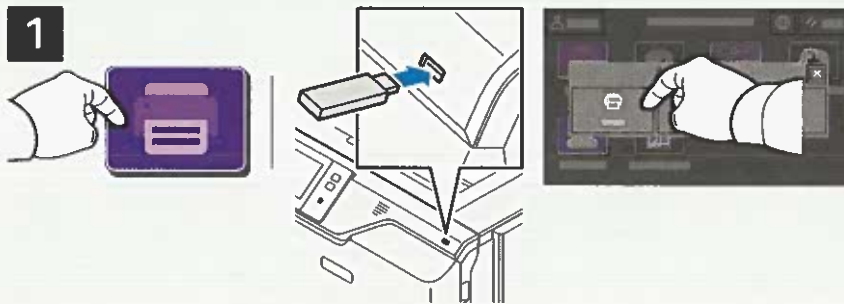

Touch **Print From** or insert your USB Flash Drive, then choose **Print From USB**.

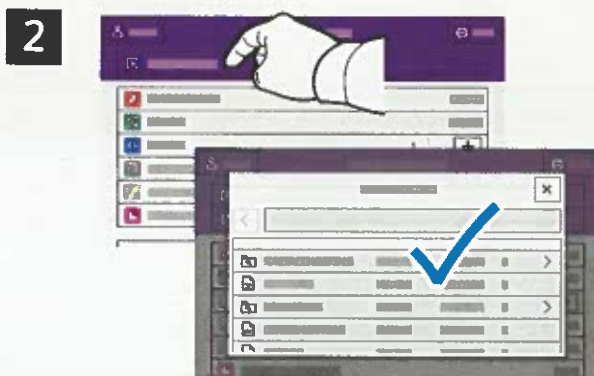

To select the number of copies, touch the plus sign (+) or the minus sign (-). For larger numbers, touch **Quantity** then enter a number.

Touch **Add Document**, then navigate to your files and select them.

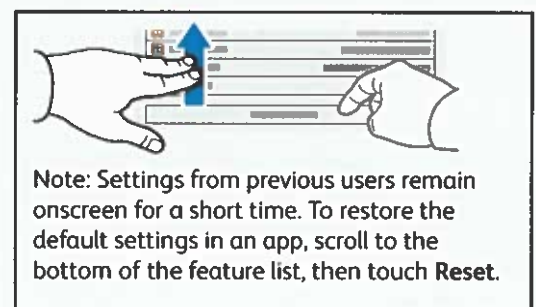

Select settings as needed, then touch **Print**.

# Printing Jobs Stored on the Printer



You can send a print job to save to the printer, then select the job from the printer control panel to print at a later time. Jobs can be saved in the public folder or be password protected. In the Xerox® printer driver, select **Properties** (Windows) or **Xerox Features** (Mac OS), then **Job Type**. Select **Saved Job** or **Secure Print**. For Secure Print, type a passcode. Click **OK** and print the job.



Touch **Print From** then touch **Saved Jobs**. Select the **Default Public Folder** then select your print job.

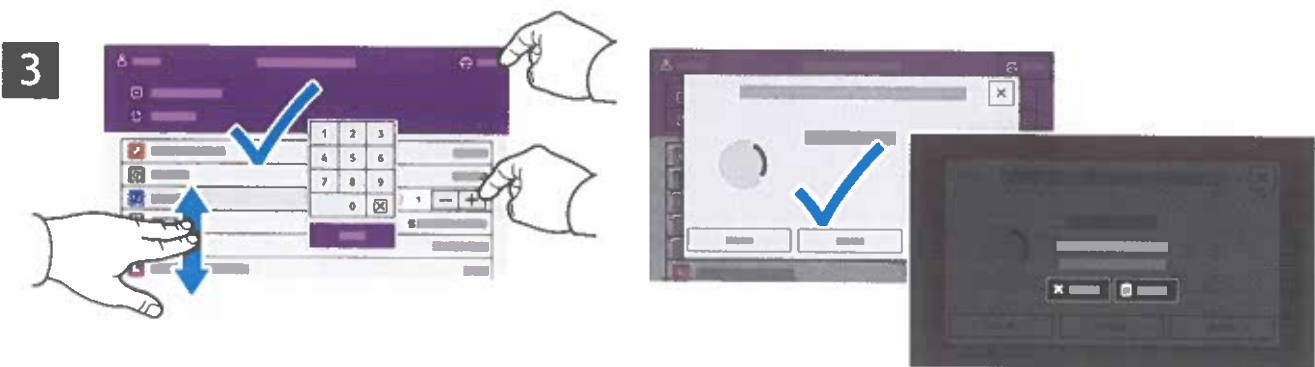

Select settings from the list. To select the number of copies, touch the plus sign (+) or the minus sign (-). For larger numbers, touch **Quantity** then enter a number. Touch **Print**. To delete the job, in the printing screen and confirmation screen, touch **Delete**.

